

ConsortiEX Verify on Receipt™ with ScanCast™ Assembly Guide

Table of Contents:

Required Zebra Hardware	2
Assembly of Zebra Scanner for use with ScanCast	2-3
Connecting a Transmitter to a Zebra EVM Fast Charging Scanner	4-5
Connecting a Receiver	6-7
Connecting a MOXA Box.....	8-11
Setup Diagrams	
<i>One Receiver</i>	12
<i>Two Receivers</i>	12
<i>Three Receivers</i>	13
<i>Four Receivers</i>	13
Moxa Connection	14

Before You Begin:

1. Access the Standard Operating Procedure, Trouble Shooting Guide, and Barcode Sheets, at any time by scanning QR code on the ScanCast module with a device **not** connected to ScanCast. (smartphone or external barcode scanner)
 - a. Alternatively, type the following into a web browser:
 https://consortiex.com/scancast-[insert Scancast model]/
 - b. Model name is on the device and packaging.
 - i. Example: <https://consortiex.com/scancast-sctx/>
2. ScanCast modules and components are color-coded. Black cables will plug into black ports, white cables to white ports, and green cables to green ports.

Required Zebra Hardware:



Zebra EVM Fast Charging Scanner P/N: DS3678-ER3U4212SVW

- Barcode Scanner P/N: DS3678ER2F003VZWW
- Cradle Charger P/N: FLB3678-C100F3WW
- DC 3600 Cable P/N: CBL-DC-451A1-01
- Power Supply P/N: PWR-BGA12V50W0WW
- AC Line Cord P/N: 23844-00-00R
- USB Cable P/N: CBA-U42-S07PAR (Not used with ScanCast)



Zebra RS232 Cable P/N: CBA-R07-S07PAR

Must Purchase Separately; Not included with Zebra EVM Fast Charging Scanner.

Assembly of Zebra Scanner for use with ScanCast:

- 1) Insert the small end of the **Zebra RS232 Cable** into **Cradle Charger**.



- 2) Connect white capped end of **DC 3600 Cable** into **Power Supply**.

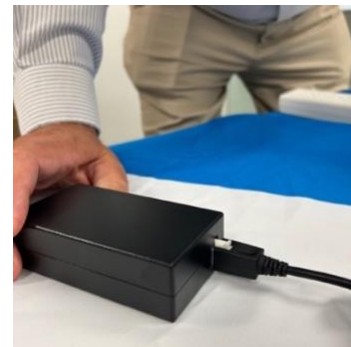

- 3) Connect **DC 3600 Cable** barrel to **Zebra RS232 Cable**. Found near thumbscrews on large end.



4) Insert **AC Line Cord** into **Power Supply**.



5) **Plug AC Line Cord** into a power source.



1. Zebra Scanner is now powered on!

Connecting a Transmitter to a Zebra EVM Fast Charging Scanner:



Box Contents:

- **Transmitter P/N: SCTX**
- **Black RJ45 Patch Cable**
- **Black Adapter**
- **Terminator**

1) Connect **Black Adapter** to **Zebra RS232 Cable**. Screw in thumbscrews.

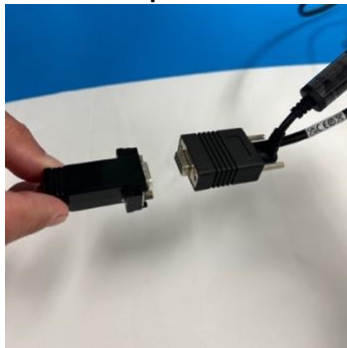

2) Connect **Black RJ45 Patch Cable** to **Black Adapter**.



3) Connect **Black RJ45 Patch Cable** to "RS232 from Barcode Scanner" side of the **Transmitter**.



4) Connect **Transmitter** USB to the laptop/computer that will be running Verify-on-Receipt.

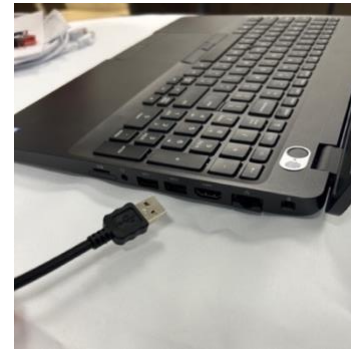

Transmitter will light up; yellow will flash slowly at first, quickly when it is ready to use.



Connecting a Receiver:



Box Contents:

- **Receiver P/N: SCRX OR MOXA Receiver* P/N: SCTM**
- **White RJ45 Patch Cable**

*MOXA Receivers must be the last module in a ScanCast chain. If you have received a BD MOXA Cable Kit follow MOXA Connection instructions on page 8-10.

- 1) Connect **White RJ45 Patch Cable** to left “RS485” side of **Receiver**.

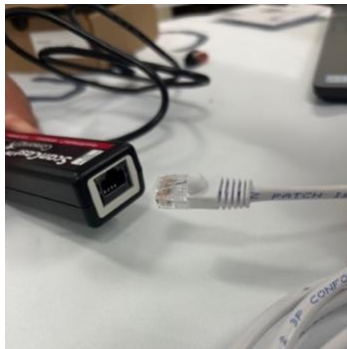

- 2) Connect the **White RJ45 Patch Cable** to right “RS485” side of the previously installed module.



- 3) If this is the last **Receiver**, insert **Terminator** into the open end of the **Receiver**.



- 4) Plug **Receiver** USB into Laptop/Computer.



Connecting a MOXA Box:



BD MOXA Cable Kit Contents:

- Green Adapter
- Green RJ45 Patch Cable
- Black Splitter
- Black Adapter
- Black RJ45 Patch Cable

1) Unplug MOXA Box and replace original scanner with **Zebra EVM Fast Charging Scanner**.

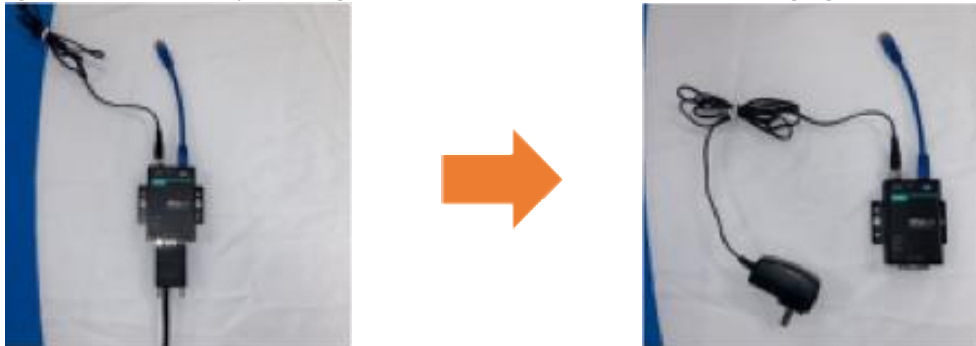

2) Connect the **Black Adapter** to **Zebra RS232 Cable**. Screw in thumbscrews.

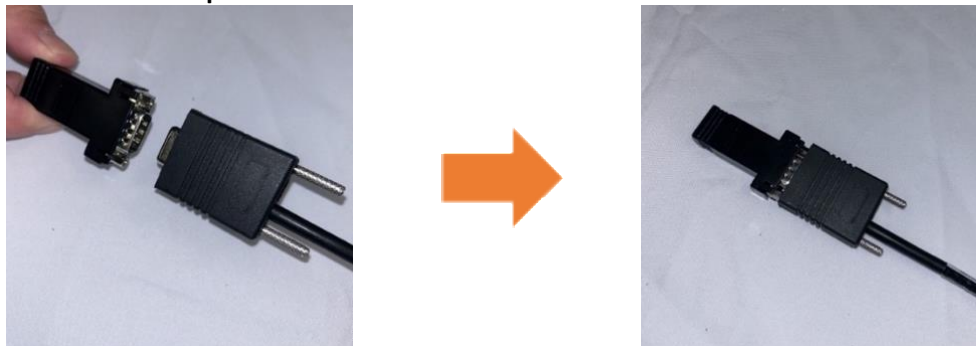

3) Insert **Black RJ45 Patch Cable** into **Black Adapter**.

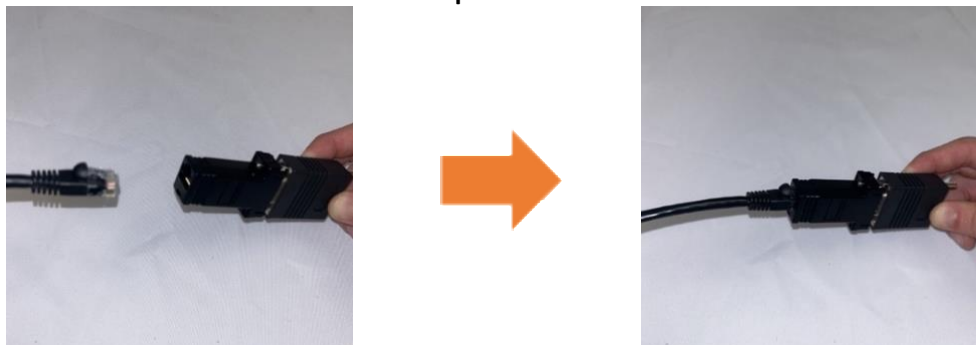

4) Connect **Black RJ45 Patch Cable** into **Black Network Splitter**.

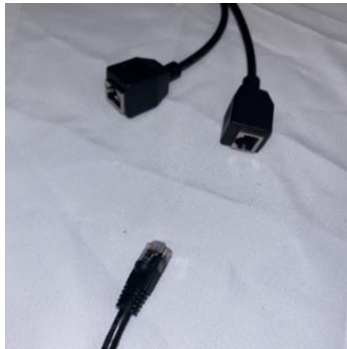

- 5) Connect **White RJ45 Patch Cable** into **Black Network Splitter**

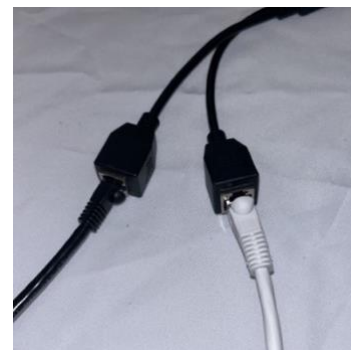
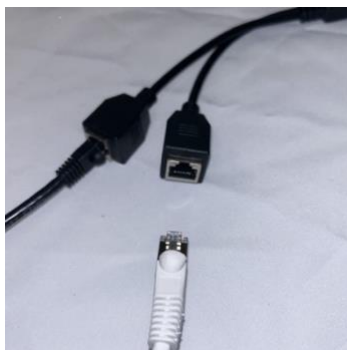

- 6) Connect **White RJ45 Patch Cable** into right "RS485" side of the previously installed module.



- 7) Insert **Black Network Splitter** into the black "RS485 from SCTX or SCRX RS232 from Barcode Scanner" side of the **MOXA Receiver**.



- 8) Connect **Green RJ45 Patch Cable** to the green "RS232 to MOXA" end of the **MOXA Receiver**.

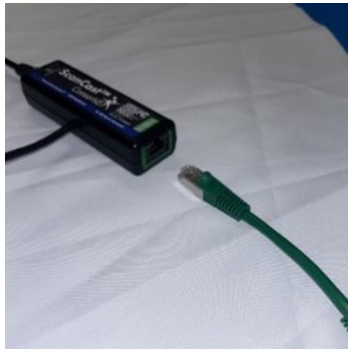

9) Insert the other end of **Green RJ45 Patch Cable** into **Green Adapter**.



10) Connect **Green Adapter** to **MOXA Box**.



11) Plug **MOXA Receiver USB** into Laptop/Computer.

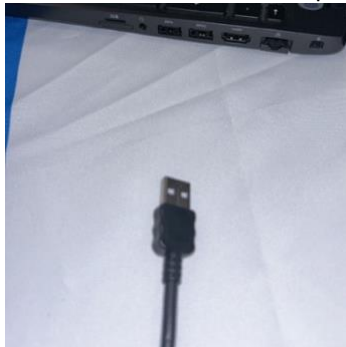

12) When plugged in and powered on, the module will light up.



Setup Diagrams:

One Receiver:

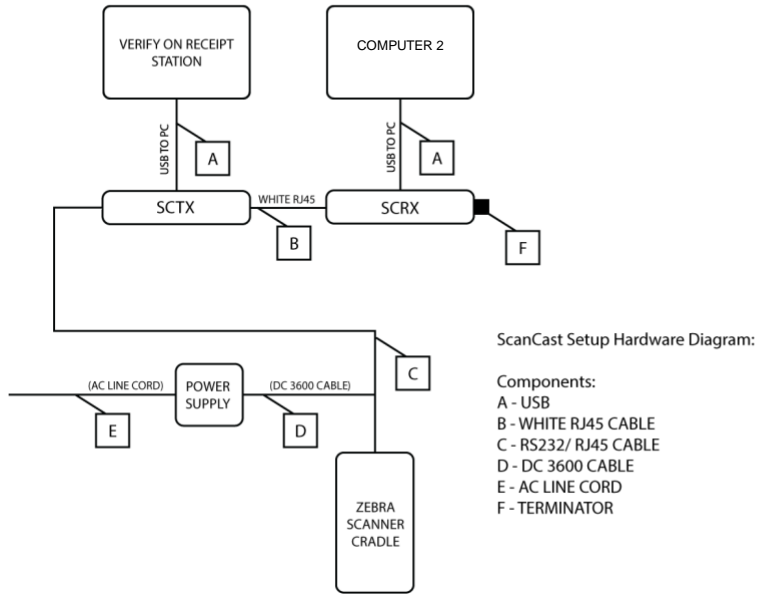

Two Receivers:

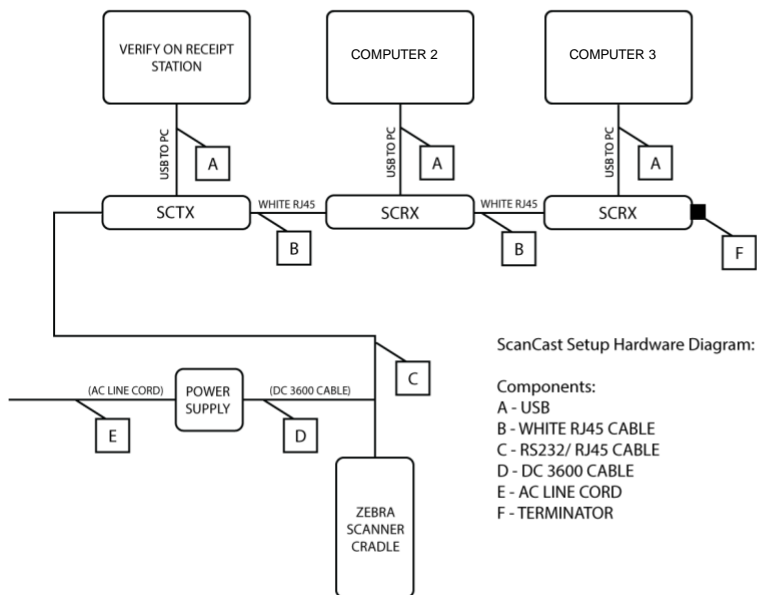

Three Receivers:

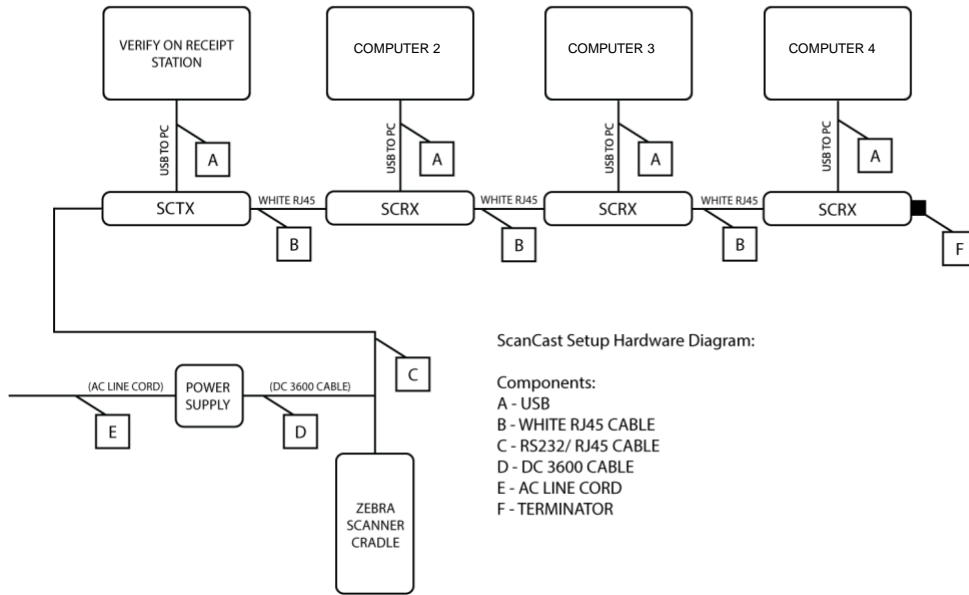

Four Receivers:

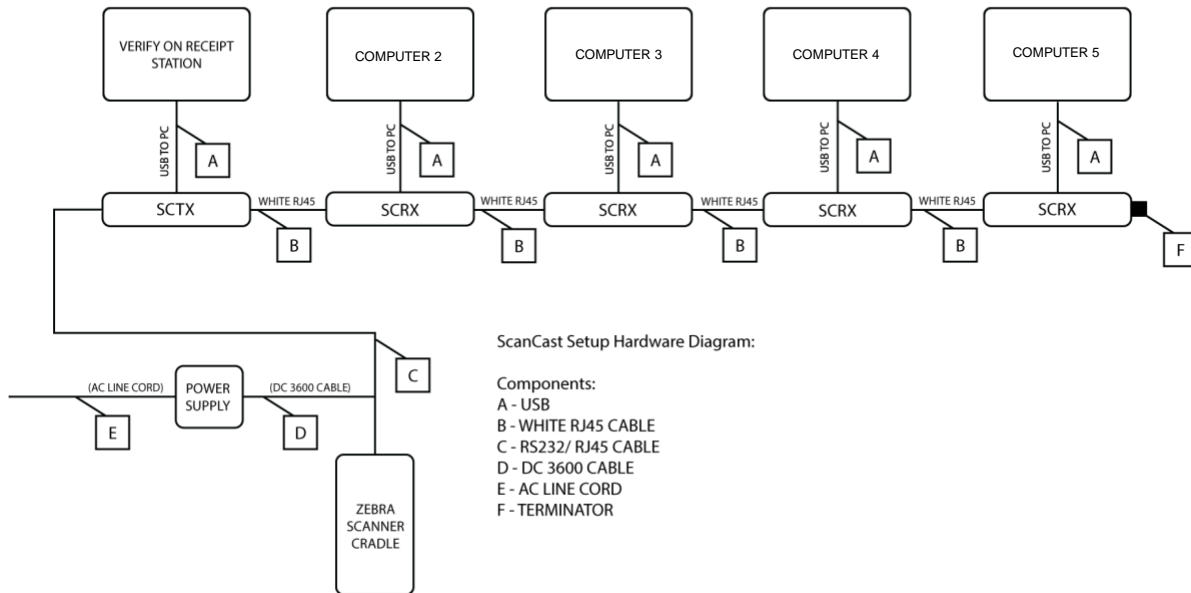

MOXA Receiver with MOXA connection:

